

SPECIFICATIONS

SPSC22B

ELECTRICAL

RESISTANCE RANGE	500 TO 50K OHMS
RESISTANCE TOLERANCE	±15%
CONFORMITY (PEAK TO PEAK)	±2%
ELECTRICAL ANGLE	360°
RESOLUTION	ESSENTIALLY INFINITE
INSULATION RESISTANCE	1000MEGOHMS @500 VDC
DIELECTRIC STRENGTH	500 VAC
POWER RATING	0.5 WATTS
OUTPUT SMOOTHNESS	<0.1% AGAINST INPUT VOLTAGE
CONTACT RESISTANCE VARIATION	BELOW 8% C.R.V.
MAXIMUM WORKING VOLTAGE	250V

MECHANICAL

NO OF TURNS	1
MECHANICAL ROTATION	CONTINUOUS
ROTATIONAL LIFE	10,000,000 TURNS
STARTING TORQUE	BELOW 0.4 OZ. IN.
WEIGHT	0.7 OZ.

ENVIRONMENTAL

OPERATING TEMPERATURE	-55°C TO +105°C
TEMPERATURE COEFFICIENT	±400p.p.m./°C
VIBRATION	10HZ TO 2000HZ 15G
SHOCK	50G
MOISTURE RESISTANCE	40°C 95%RH 120 HOURS

MATERIALS

HOUSING	ANODIZED ALUMINUM
SHAFT	STAINLESS STEEL
TERMINALS	GOLD PLATED BRASS
RESISTANCE ELEMENT	CONDUCTIVE PLASTIC

OPTIONAL FEATURES

- SHAFT MODIFICATIONS
- REAR SHAFT
- O'RING SHAFT SEAL
- BUSHING MOUNT
- MULTIPLE SECTIONS

SCHEMATIC

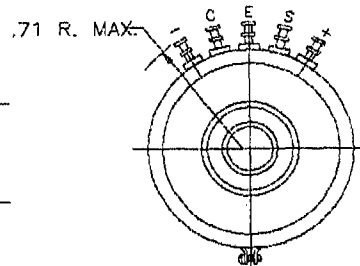
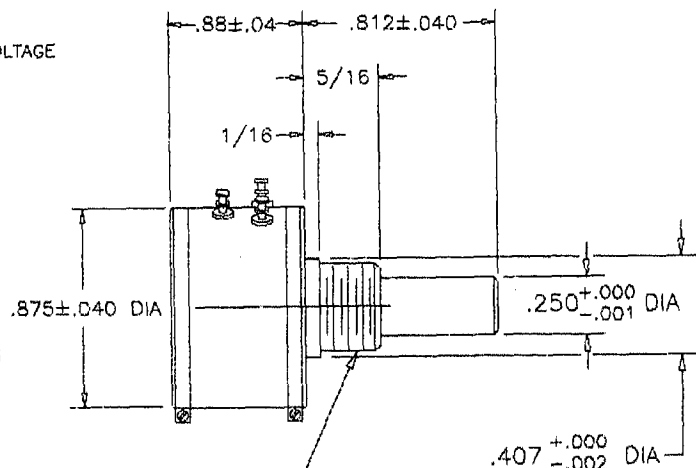
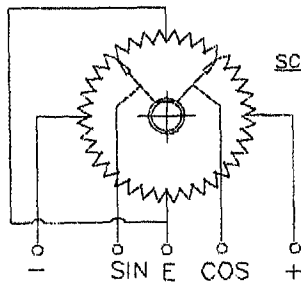

3/8-32 UNEF-2A THREADED BUSHING
FURNISHED WITH NUT & LOCKWASHER

Precision Sales Inc
www.precisionsales.com
eparts@precisionsales.com
610-359-1002