

# W15 Series

## Low Cost, Reset Totalizer

### Features

- Super Low Power
- 5 Digits
- 3 Mounting Styles
- 2 Termination Types
- Resettable
- Optional Extended Temperatures
- Low Cost

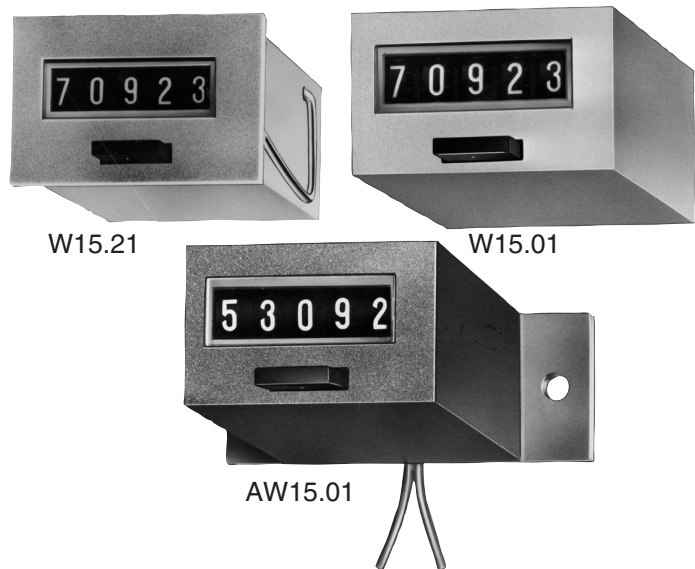

### Applications:

W15 Series counters are well suited for battery operated traffic counters, vending machines, message accounting systems, and general event counting where a reset is required.

### Description:

The W15 Series 5 digit counters combine low 60mW power and reset capability in a small housing just .790" high and 1.22" wide. The proven armature phase system combined with an anti-shock/vibration driving system provides a high degree of counting accuracy. Wear-resistant plastic insures a high rate of maintenance free service life.

### Specifications:

**Digits:** Five 0.067" white on black.

**Weight:** 1.8 oz.

#### Operating Voltages:

3, 4, 6, 9, 12 VDC filtered  $\pm 5\%$

4, 6, 12, 24, 48, 110, 185 VDC  
unfiltered  $\pm 10\%$ .

12, 24, 48, 110, 220 VAC.

**Reset:** Manual, front push-button

**Count Speed:** 10 cps standard; 8 cps (low power-filtered)

**Max. on Time:** continuous

**Temperature:** +14°F to +122°F (-10°C to +50°C) standard.

-22°F to +158°F (-30°C to +70 °C) optional.

**Termination:** Wire leads 6" long or silver-plated pins 0.060" dia.

**Color of Housing:** Black

**Approvals:** CE Approved

Voltage	Model	Max. Pulse Speed	Pulse Duration Min.	Pulse Interval Min.	Power Consump. Approx.
VDC	Filtered	8	50 mS	75 mS	60 mW
VDC	Non-filtered	10	50 mS	50 mS	0.5W ( $\leq 110V$ ) 1W (185V)
VAC		10	50 mS	50 mS	0.75 VA ( $\leq 110V$ ) 1.5 VA (220V)

### W15.01

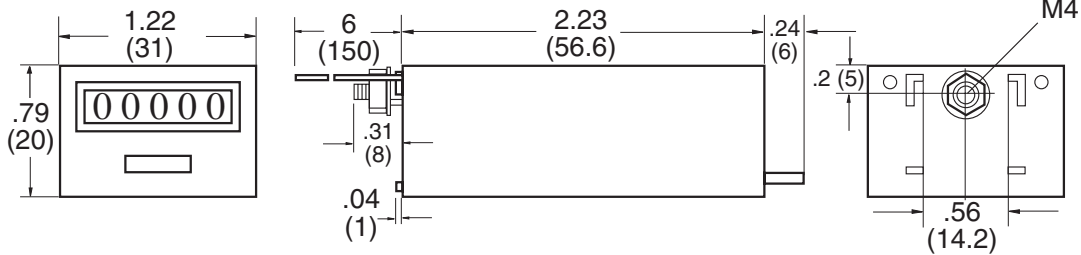

### W15.21

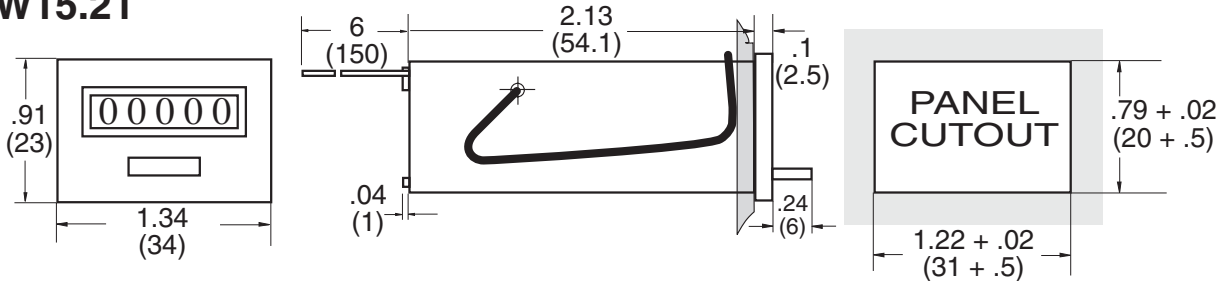

### AW15.01

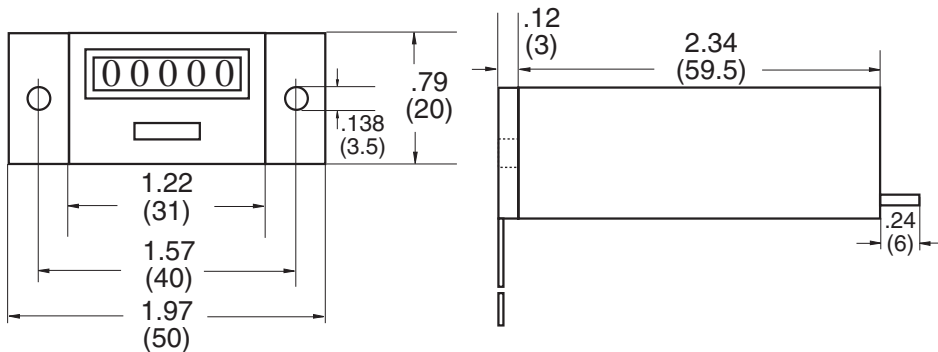

#### How To Order:

Series	Termination	Operating Voltage	Count Speed
EXAMPLE: W15.01	.3	5VDC	10CPS
AW15.01 = Base mount W15.01 = Rear stud mount W15.21 = Spring clip mount	.3 = .060" (1.5mm) Solder pins (not available with AW type) .2 = Wire leads 6" long	(specify, see count speed) DC: 3, 4, 6, 9, 12, 24, 110, 185 AC: 12, 24, 110, 220	8 CPS: 60 mW DC; available voltages 3, 4, 6, 9, 12 VDC 10 CPS: 500 mW DC; available voltages 4, 6, 12, 24, 110, 185 VDC 10 CPS: .75 VA; available voltages 12, 24, 110VAC; 1.5 VA, 220 VAC
Options	Extended temperature: -22°F to +158°F (-30°C to +70°C) add prefix "HT" to part number		